TABLE OF CONTENTS

I.	INTRODUCTION	-----	1
II.	FEATURES	-----	1
III.	ASSEMBLY	-----	2
IV.	PRECAUTIONS	-----	3
V.	KEYPAD	-----	3
VI.	FUNCTION SETTING	-----	4
VII.	OPERATION	-----	6
VIII.	WEIGHING UNIT CONVERSION	-----	6
IX.	FACTORY SETTING	-----	6
Appendix 1	ERROR MESSAGE	-----	7
Appendix 2	RS-232 FORMAT	-----	7

I. INTRODUCTION

Thank you for your purchase of JADEVER high precision electronic weighing scale, which enables you to measure both quantity and weight. The scale is easy to operate, precise, stable and with fast display reaction. It is applicable in the electronic, hardware, plastic, medicine, textile and various other industries. It is useful for packaging, inventory and various production and quality control cases. It will help you save your time, labor, money, and reduce material waste, lower cost, improve your work efficiency, thus to achieve maximum return on investment.

II. FEATURES

1. The microprocessor in this scale features
 - (1) Zero point tracking function.
 - (2) Tare and pre-tare function.
2. Easy operating and water-resistant membrane keypad.
3. Easy to read LCD display.
4. Counting function is applicable, with backlight function.
5. Tare range is unlimited.
6. The case shell is made of ABS shockproof plastics; stainless steel weighing pan is used for long-term operation.

III. ASSEMBLY

A. Models LPWN-1530 □ LPWN-7515 LPWN-1530K

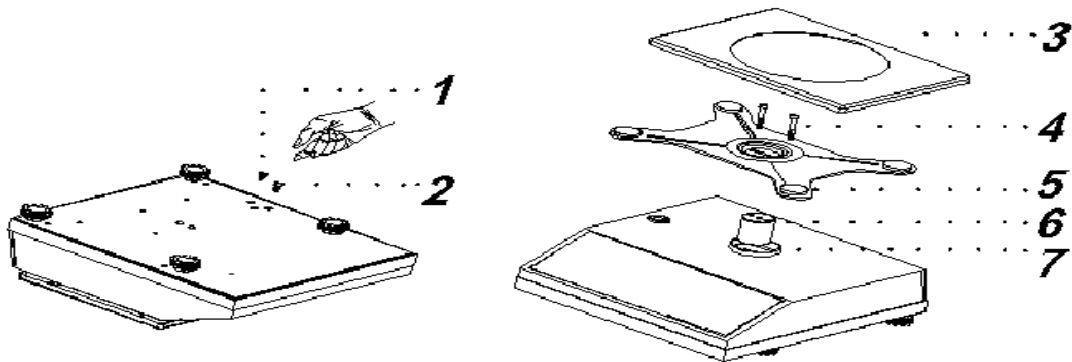

1. Remove the protection copper screw [2], and then screw out the protection copper screw [1];
2. Align the three-hole aluminum column [6] and center of the three round holes on the scale support [5] with the corresponding hole on the “-” shaped iron piece inside hole [7]. Then fix the three-hole aluminum column [6] and scale support [5] on the “-” shaped iron piece of the scale by tightening the M5 Allen screw [4] using an Allen wrench;
3. Put the stainless steel weighing pan [3] on the scale support [5].

B. Model LPWN-3075

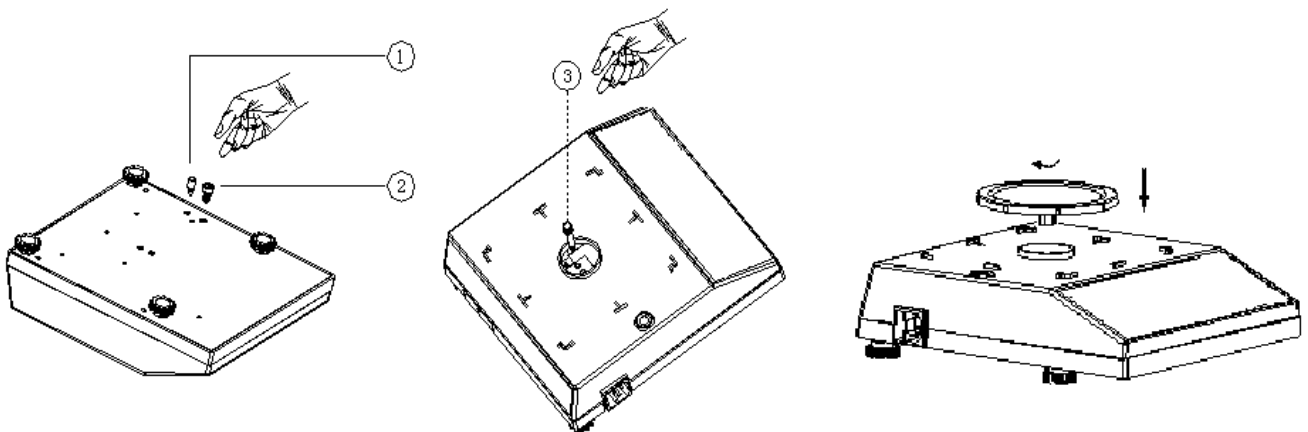

1. Remove the protection copper screw [2], and then screw out the protection copper screws [1] & [3];
2. Screw in the round weighing pan clockwise and downwards.

C. Model LPWN-150

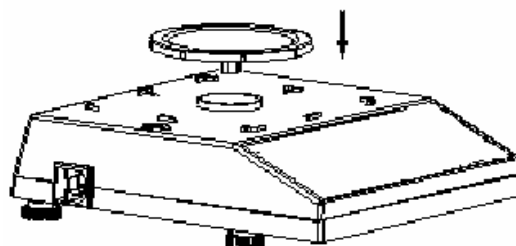

1. Place the round weighing pan directly onto the scale support.

D. Wind Shield

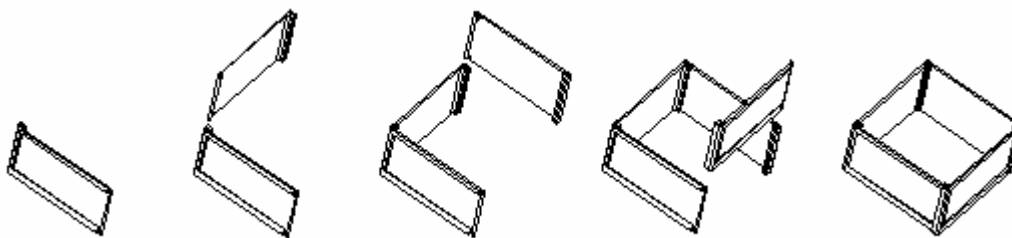

Note: Always reinstall the transportation protection device before transporting the scale, lest the precision sensor should be damaged due to bumping and falling during transportation.

IV. PRECAUTIONS

1. Full charge the battery after unpacking the scale.
Recharge the battery: When battery symbol appears on the LCD display, charge the battery with AC power cord plug in, the indicator of charge will light up in red; when it becomes green means charge completed. (It takes about 8 hours to full charge the battery.)
2. Install the equipment on a level and stable surface.
3. Do not install the equipment near the air conditioning or a vibrating machine.
4. Install the equipment in an environment with steady temperature (0□~40□), avoid rapid temperature changes.
5. Independent AC outlet for this equipment is recommended, check the voltage before plug in.
6. Warm up the equipment for 15 minutes before use.

V. KEYPAD

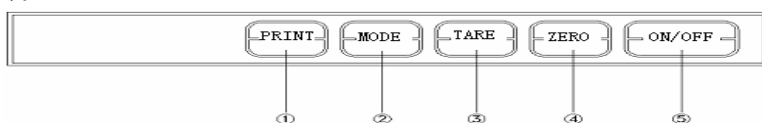

1. "PRINT"

Press **PRINT** key, RS-232 will print data, when negative value is shown on the screen, the printing function is prohibited.

2. "MODE"

Press **MODE** key for selecting weighing unit.

3. "TARE"

Press **TARE** key for deduction of current weight on the weighing pan. After removing the weight on the weighing pan, press **TARE** key to cancel the original tare.

Note: This operation can only be performed in the stable mode.

4. "ZERO"

Press **ZERO** key and the screen will show **zero 0.0000**, press **ZERO** key in the tare mode, the tare will be cancelled; if the weight on the weighing pan is within the zero adjustment range, the scale will be reset to zero.

5. "ON/OFF"

Power switch.

Cross reference list of keys in Chinese and English

ENGLISH	ON OFF	TARE	ZERO	PRINT	MODE

VI. FUNCTION SETTING

LCD Display	Function	Selection	Reference
CAL	Model display		Page 4, Item 1
↓			
UON	Weighing unit	ON/OFF	Page 5, Item 2
↓			
Init	Initial unit	Kg/g/lb/lb-oz/Taiwan jin/HK jin, etc.	Page 5, Item 3
↓			
Fil	Filter	1/2/3/4	Page 5, Item 4
↓			
Auto	Auto power off	OFF/5/10/30/60	Page 5, Item 5
↓			
Ligh	Backlight	OFF/ON/AUT	Page 5, Item 6
↓			
Lit	Zero point range	0/1/2/3/4/5	Page 5, Item 7
↓			
Baud	RS-232 baud rate	2400/4800/9600	Page 5, Item 8
↓			
rS232	Printing mode	Co/St/ Pr	Page 5, Item 9
↓			
Print	External device	PC /SH/EZ	Page 5, Item 10
↓			
Stabl	Printing stability	Yes/No	Page 5, Item 11

1. Power on while holding down **MODE** key. The scale will enter into function setting mode and **CAL** appears on the LCD display. Press **PRINT** key, the LCD display will show the scale model e.g. **3 kg**.

2. Press **MODE** key once again, the LCD display will show **UON**, which means the scale enters into weighing unit setting mode. Press **PRINT** key to select unit, press **TARE** key to enable (ON) or disable (OFF) the weighing unit. If the display shows **ON kg**, it means the unit shown will be used; **OFF kg** means the unit shown will not be used. Press **MODE** key once again, the LCD display will show **Init**, which means the scale enters into initial weighing unit setting mode; press **TARE** key to select initial unit setting.

3. If the LCD display shows **Init g**, it means “g” is the initial weighing unit when power on. Available units: kg, g, lb, lb-oz, jin, HK jin, Taiwan jin.

4. Press **MODE** key once again, the LCD display will show **Fil**, which means the scale enters

into filter setting mode; press down **TARE**, the display will show **Fil 2**, press **TARE** key again to switch the filter degree as 1, 2, 3 or 4. Level 4: Reaction is slower, effect on filtering is higher.

5. Press **MODE** key once again, the LCD display will show **Auto**, which means the scale enters into auto power off setting mode; press **TARE** key to select the time of auto power off. 5, 10, 30, or 60 minutes means the lasting time value when the scale is at the non-tare zero point. In such mode, the scale will be powered off automatically after elapse of the set time.

6. Press **MODE** key once again, the LCD display will show **Ligh**, which means the scale enters into backlight setting mode. Press **TARE** key to select setting, if the display shows **OFF**, it means the backlight is off; **ON** means the backlight is on; **Auto** means auto backlight is on.

7. Press **MODE** key once again, the LCD display will show **Lit**, press **TARE** key, **d1** will appear on the display, press **TARE** key again to select zero tracking range. 0, 1, 2, 3, 4 or 5 can be selected (the bigger the number is, the larger zero tracking range is).

8. Press **MODE** key once again, the LCD display will show **BAud**, which means the scale enters into baud rate setting mode; press **TARE** key to select the transmission rate of 2400, 4800, or 9600.

9. Press **MODE** key once again, the LCD display will show **RS232**, which means the scale enters into printing mode setting mode, press **TARE** to select **Prt Co**, **Prt St**, or **Prt Pr** (Pr means data sent when key pressed; St means data sent automatically when stable symbol shown; Co means data sent continuously).

10. Press **MODE** key once again, the LCD display will show **Print**, which means the scale enters into printing mode setting mode, press **TARE** to select **PC**, **SH**, or **EZ**.

11. Press **MODE** key once again, the LCD display will show **Stabl**, which means the scale enters into printing stability judgement setting mode, press **TARE** key to select setting, **YES** means the data can be printed out by pressing **PRINT** key only in the stable mode; **No** means the stable mode will not be detected. Press **MODE** key to reset each function. Press **ZERO** key anytime when a function setting is completed. This will make the scale return to normal weighing mode.

VII. Operation (after normal power-on)

Counting: (simple counting function)

Press **MODE** key, the LCD display will show **0 PCS**, press **TARE** key, **CAL** will appear, put the samples on the weighing pan, press **TARE** key again to select the counting standard needed (25, 50, 100); wait until automatic sampling by the scale, and new number is shown on the display, it is ready for counting operation.

Percentage:

Press **MODE** key until the LCD display shows **0 %**, press **TARE** key, **CAL** will appear; put the samples on the weighing pan, press **TARE** key again to select the counting standard needed (25, 50, 100); wait until automatic sampling by the scale, and new number is shown on the display, it is ready for percentage counting operation.

VIII. WEIGHING UNIT CONVERSION

1 kg = 1000 g	1 = 500g
1 HK jin = 16 HK ounce	1 HK ounce = 37.799375g

1 Taiwan ounce = 37.49995g	1 Taiwan jin = 16 Taiwan ounce
1 lb = 453.59237g	1 oz = 28.3495231g

IX. FACTORY SETTING

A. LINEAR CALIBRATION

1. Power on while holding down **TARE** key, the display will show **Line**.
2. Press **MODE** key to enter into automatic factory calibration mode, the display will show **On0**, put weight of 1/3 full load on the weighing pan when **On1** appears, press **TARE** key until **On2** appears, put weight of 2/3 full load on the weighing pan, press **TARE** again, **On3** will appear on the display, press **TARE** after putting weight of full load on the weighing pan and wait until **PASS** appears.
3. Take off the weight, press **ZERO** key to return to weighing mode.

B. SINGLE-POINT CALIBRATION

1. Power on while holding down **MODE** key to enter into setting mode, the display shows **CAL**.
2. Press **TARE** key to enter into single-point calibration mode, the display will show **On0**, wait until **CAP** appears.
3. Press **MODE** key to select calibration weight, the display will show in turn **CAP 1**, **CAP2**, and **CAP3**; put corresponding weights of 1/3, 2/3 or full load on the weighing pan, then press **TARE** key to enter into single-point calibration mode, wait until the display shows **PASS**.
4. Take off the weights, press **ZERO** key to return to weighing mode.

C. PRECISION SETTING- (Only applicable for version 2.0 and above)

1. Power on while holding down **PRINT** key to enter into setting mode, the display will show **SEnC**.
2. Press **TARE** key to select **SEnC1** or **SEnC2**.
3. SEnC1 means precision 15000, SEnC2 means precision 6000 (7500).
4. After setting is completed, press **ZERO** key to return to weighing mode.

APPENDIX 1: ERROR MESSAGE

1. Error message

Err. Msg.	Problem	
Err2	Initial zero point over $\pm 10\%$ (take 10% as the benchmark)	
Err3	Over or below A/D resolution range FFFFF	
Err4	EEPROM Chksum error	
Err5	Overload (max. capacity $+9e$)	
Err6	Wrong calibration weight	
Battery symbol	Low battery	

2. Troubleshooting

When	Err. Msg.	Troubleshooting
Power on	Err2	Check and remove any object from weighing pan or malfunction of LOAD CELL
Power on	Err3	Check if A/D or LOAD CELL malfunctions

Power on	Err4	Beep alert. Switch power off and power on again, or perform calibration
Power on	Battery symbol	Charge the battery with power on
Operating at normal weighing mode	Err5	Checking if the weighing object is over the max. capacity +9e
Calibrating	Err6	Change weight

APPENDIX 2:

RS-232 OUTPUT FORMAT

Baud Rate 2400, 4800, 9600

Data Bit 8

Parity N (None)

Stop Bit 1

Code ASCII

Bit Format

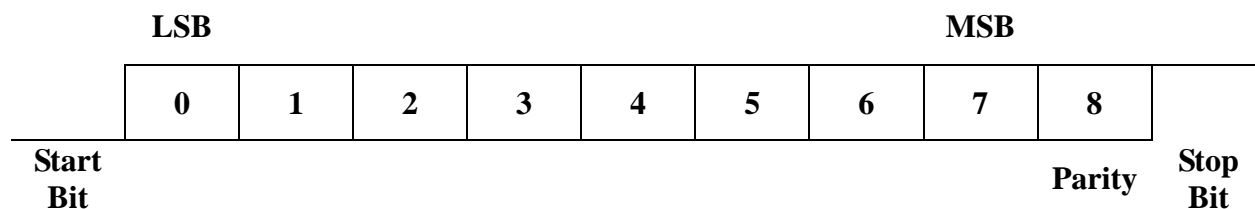

Data Format

1. kg

G/ N	.	W	.		+/-									k	g	C R	LF
---------	---	---	---	--	-----	--	--	--	--	--	--	--	--	---	---	--------	----

weight

Example:

N.W. + 1.1375kg

T.W. + 0.0180kg

G.W. + 1.1555kg

2. g

G/ N	.	W	.		+/-									g	C R	LF
---------	---	---	---	--	-----	--	--	--	--	--	--	--	--	---	--------	----

weight

Example:

N.W. + 1137.5g

T.W. + 18.0g

G.W. +1155.5g

3. lb

G/ N	.	W	.		+/-									l	b	C R	LF
---------	---	---	---	--	-----	--	--	--	--	--	--	--	--	---	---	--------	----

weight

Example:

N.W. +2.508lb

+ 0 %

G = GROSS

N = NET

T = TARE

Printer and output format (example: kg)

SH-24	EZ2-S
N.W.:+1.6025 kg	N.W.:+ 1.1375 kg
T.W.:+0.0000 kg	T.W.:+ 0.0180 kg
G.W.:+1.6025 kg	G.W.:+ 1.1555 kg

RS-232 Connector/ Signal Output

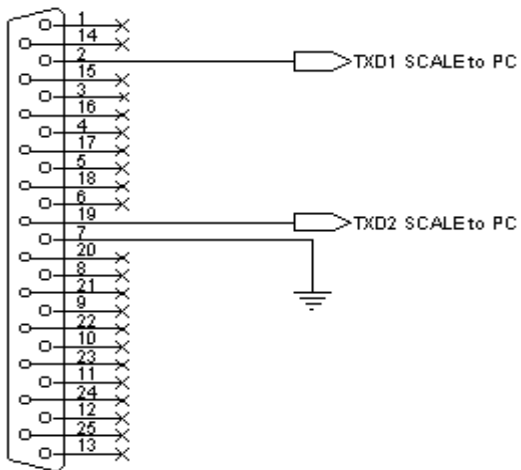

CONNECTOR DB25